

Non-contact Tonometer

Instruction Manual

CHONGQING SUNKINGDOM MEDICAL INSTRUMENT CO.LTD.

Catalog

Catalog.....	2
Preface.....	4
1. Overview	
1.1 Introduction of Equipment.....	6
1.2 Usage notice.....	7
1.3 Structure and Composition.....	8
1.4 Range of application.....	8
1.5 Product contraindications.....	8
1.6 Matters need attention.....	9
1.7 Shapes and Sizes.....	10
1.8 Equipment operating environment conditions.....	10
1.9 Transport and Storage.....	10
1.10 Symbol interpretation.....	10
2. Technical index.....	
2.1 Product features.....	11
2.2 Performance.....	12
3. Equipment installation instructions.....	16
3.1 Product structure.....	16
3.2 Equipment packaging and accessories description.....	17
3.3 Installation Environment.....	18
3.4 Installation.....	18
4. Introduction and settings of interface.....	19
4.1 Introduction of main interface.....	19
4.2 Interface of safety distance setting.....	21
4.3 ID input interface.....	22
4.4 Menu interface.....	23
5. Instructions for operating.....	28
5.1 Software description.....	28
5.2 IOP/corneal measurement.....	28
6. Maintenance of Equipment	29
6.1 Daily maintenance.....	29
6.2 Maintenance during equipment operation.....	29
6.3 Maintenance of long-term parking equipment.....	29
6.4 Parts replacement.....	30
6.5 Waste disposal.....	30
6.6 Manufacturer's responsibility.....	30
6.7 Common troubleshooting.....	31

7.	Information requirements of Electromagnetic compatibility.....	32
7.1	Equipment classification.....	32
7.2	Basic performance.....	32
7.3	Electromagnetic emission.....	32
7.4	Electro Magnetic Immunity.....	33
7.5	EMI---For non-life support equipment and systems.....	34
7.6	Recommended isolation distance between portable and mobile RF communication equipment and non-contact tonometer.....	35
7.7	Installation Environment.....	36
7.8	Appurtenance list.....	36
8.	Warranty statement.....	38

Preface

Respected user:

Thank you for choosing to use the non-contact tonometer produced by CHONGQING SUNKINGDOM MEDICAL INSTRUMENT CO.LTD.(hereinafter referred to as "Sunkingdom")."Sunkingdom" non-contact tonometer can be trusted by you, we are deeply honored.In order to give you an overall understanding of the "Sunkingdom" non-contact tonometer, we have configured this instruction manual for you, which includes the introduction of the equipment, installation, usage, instructions for use, maintenance, transportation, storage, etc. It is an indispensable guide for you to use this equipment.

In order to enable you to better understand the relevant knowledge of the equipment, please read the instruction manual carefully before use, I believe it will be very helpful for you to use the equipment effectively.

Register Information

- ◆Product name: Non-contact tonometer
- ◆Product model: SK—5000A,SK—5000B
- ◆Manual model: SK—5000A,SK—5000B
- ◆Registrant/manufacturing company name: CHONGQING SUNKINGDOM MEDICAL INSTRUMENT CO.LTD.
- ◆Registrant/manufacturing company domicile: No. 1 Xinmao Road, Beibei District, Chongqing (FTA)
- ◆Registrant/manufacturer contact information: 023-68102805
- ◆Product production address:
35-2,YINGTIANGUANGDIANGONGGU,CAIJIAGANG INDUSTRY,BEIBEI DISTRICT, CHONGQING
- ◆Product registration address: No. 1 Xinmao Road, Beibei District, Chongqing (FTA)
- ◆Production license number:
- ◆Registration certificate number:
- ◆Technical requirement number:
- ◆After-sales service company name: CHONGQING SUNKINGDOM MEDICAL INSTRUMENT CO.LTD.
- ◆After-sales service address:
35-2,YINGTIANGUANGDIANGONGGU,CAIJIAGANG INDUSTRY,BEIBEI DISTRICT, CHONGQING
- ◆After-sales service phone: 023-65102805
- ◆Production date of this product: See product nameplate
- ◆Product life: 5 years
- ◆Date of preparation of the manual: February 2, 2021
- ◆Manual version number: 1st edition

It is recommended that you do the following carefully before use:

- 1. First carefully check whether the equipment is consistent with the packing list, and whether the instruction manual and accessories are complete.**
- 2. Please read the accompanying documents carefully and keep them properly.**

The pictures in this manual are renderings, and the specific configuration is subject to the packing list. If you have any questions, please consult CHONGQING SUNKINGDOM MEDICAL INSTRUMENT CO.LTD.

Tel: 023-68102805

1.Overview

1.1 Introduction of Equipment

1.1.1 Introduction of product

The non-contact tonometer absorbs the advantages of international advanced models, and has higher stability and reliability compared with similar domestic products. This product is used to measure intraocular pressure and corneal thickness. It has the characteristics of fully automatic focusing, quiet operation, and fully automatic air puff pressure measurement.

1.1.2.1 Product Model

SK - □□□□ □

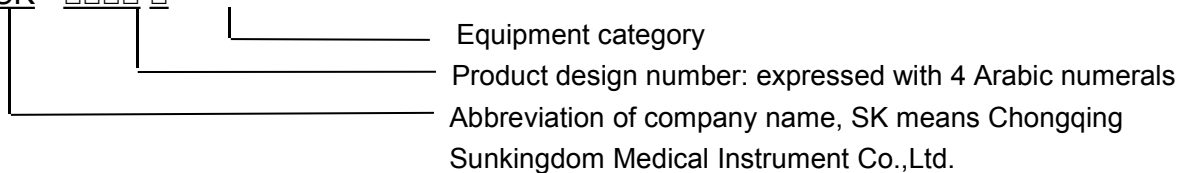

Marking example: SK-5000A means a non-contact tonometer of model SK-5000A produced by Chongqing Sunkingdom Medical Instrument Co., Ltd.

1.1.2.2 Software model

SK - □□□□

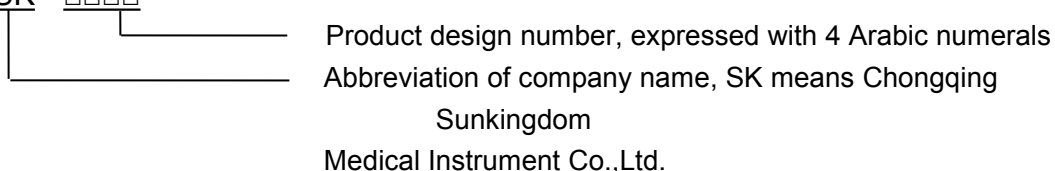

Marking example: SK-5000, which means the SK-5000 non-contact tonometer system software produced by Sunkingdom Medical Instrument Co.,Ltd.

1.1.2.3 Software version naming rules

V X.Y.Z

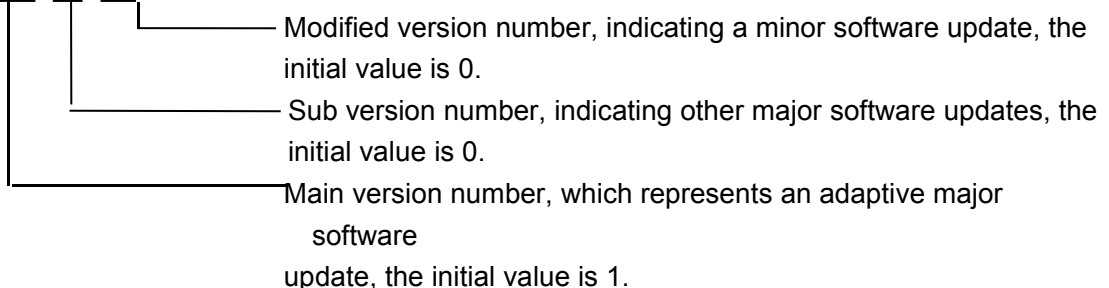

Marking example: V1.0.0 means that the main version number of Chongqing Sunkingdom Medical

Instrument Co., Ltd.is 1, the sub number is 0, and the revised version number is 0. The full version is V1.0.0, and the release version only includes the main version number. And the sub version number is V1.0.

1.1.3 Product model list

Form1 List of product models

Model	Composition	Main function	Embedded software components		
			Name	Model	Version
SK-5000A	Host, Power cord, Software	Fully automatic platform, intraocular pressure measurement	Sunkingdom non-contact tonometer system software	SK-5000	V1.0
SK-5000B	Host, Power cord, Software	Fully automatic platform, intraocular pressure measurement, corneal thickness measurement, etc.	Sunkingdom non-contact tonometer system software	SK-5000	V1.0

1.2 Usage notice

1.2.1 For your safety and benefit, please read this product manual and all the accompanying materials carefully before using the equipment. If you fail to use and operate the equipment in accordance with the product manual, our company will not be liable for any personal injury, property or other losses caused by it.

1.2.2 This product cannot be used simultaneously with high-frequency surgical equipment.

1.2.3 The voltage at the location of the equipment must reach the voltage required by the equipment.

If the voltage is unstable, please equip yourself with voltage stabilizing equipment. The company is not responsible for equipment problems caused by voltage.

1.2.4 To prevent the device from being damaged by the environment (humidity, dust, liquid, direct exposure to the sun, etc.), it should be placed in a dry place. Please prevent liquid or other debris from entering the device, otherwise it may cause a short circuit of the internal parts of the device, which may cause electric shock or fire.

1.2.5 You can't open the equipment shell without authorization of our company, otherwise our company will not be responsible for any consequences caused.

1.2.6 In order to maintain the equipment, if you need to turn it on again after turning off the power, you need to wait for more than 5 seconds.

1.2.7 When you are not using the device, please unplug the power plug in time. Do not leave the device energized for a long time. Generally, continuous work is limited to 4 hours. Please keep the equipment clean.

1.2.8 Environmental protection clause: When equipment or components are damaged or reach the end of their service life, random discarding may cause environmental pollution, and they should be recycled or scrapped in accordance with local laws and regulations.

1.2.9 About this instructions manual of product (hereinafter referred to as "manual")

1) The pictures in this manual are renderings, and the content is subject to the actual product.

2) If you are unclear with any content or terms of the manual, or if you encounter technical problems during the use of the equipment, you are welcome to call: 023-68102805 Supervise Tel: 023-68102791.

3) The company reserves the right to interpret and modify the instructions.

1.2.10 The chin rest where the tonometer touches the patient are wrapped with disposable medical absorbent cotton gauze.

1.3 Structure and Composition

The product consists of a host, power cord and software.

1.4 Range of application

Used for eye examination to measure intraocular pressure and corneal thickness (applicable to SK-5000B).

1.5 Product contraindications

【Contraindications】

Use with caution for severe corneal disease (Such as: edema, scars, etc.)

Use with caution if there are corneal diseases (such as edema, scars, etc.);

Use with caution for infectious corneal lesions.

1.6 Matters need attention

 To avoid personal injury and other possible dangers, please read the matters need attention carefully;

 Warning: This device cannot be used for fetuses;

 Warning: Before wiping the equipment, disconnect the external power supply;

 Warning: Every time you turn off the device, you need to disconnect the external power supply;

 This equipment must properly grounded for safe operation.

 This equipment can only be used by inspectors, no need to do allergy test.

 Equipment installation should be carried out on a flat and non-inclined ground;

 Keep the working environment of the equipment clean and dry, and avoid using it in an overheated and dusty environment;

 Use the wire that the equipment is equipped with at the factory;

 Do not use sharp instruments or hard objects to scratch or touch the surface of any exposed part of the equipment;

 Warning: This equipment cannot be used with high-frequency surgical equipment;

 Warning: Without the authorization of the company, you can not open the shell, otherwise you will be responsible for the consequences;

 Warning: A grounded power plug must be used.

1.7 Shapes and Sizes

Form2 Product Size

SIZE	MODEL	SK-5000A, SK-5000B
SIZE (L×W×H) (mm)		460×290×460

1.8 Equipment operating environment conditions

- ◆Environmental temperature: 10°C~35°C.
- ◆Relative humidity: 30%-75%
- ◆Atmospheric pressure range: 700hPa~1060hPa
- ◆Power supply: a.c.220 V, 50 Hz











1.9 Transport and Storage

The packaged equipment can be transported by general transportation. Avoid rain and snow and collisions during transportation, and cannot be upside down or exposed to the sun.

The packaged equipment should be stored in a clean room with an ambient temperature of 0°C~55°C, a relative humidity of not more than 85%, and an atmospheric pressure of 700hPa~1060hPa, and a well-ventilated, dry, and non-corrosive gas.

1.10 Symbol interpretation

Form3 Symbol

 Power on	 Power off
 Chin rest moves up	 Chin rest moves down
 Type B application part	 Note! Check random files
 Limit switch	 Fully automatic measurement of left and right eyes
 ON	 OFF

Symbols on the packing box:



There are fragile items in the transport package, so please handle it carefully.

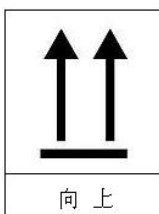

The package should be upright during transportation.



The package is afraid of rain.

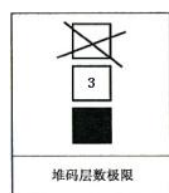

The package can be stacked up to 3 layers.

2. Technical index

2.1 Product features

- 1) Classified according to the type of electric shock protection: Class I equipment;
- 2) Classified according to the degree of protection against electric shock: Type B applied part;
- 3) Classified according to the degree of protection against ingress of liquid: Ordinary equipment;
- 4) According to the safety degree of flammable anesthetic gas mixed with air or flammable anesthetic gas mixed with oxygen or nitrous oxide: Do not use in the case of flammable anesthetic gas mixed with air or flammable anesthetic gas mixed with oxygen or nitrous oxide;
- 5) Classified by operating mode: Intermittent loading and continuous operation;

- 6) Rated voltage and frequency of the equipment: a.c. 220 V, 50 Hz;
- 7) Input power of the equipment: 300VA;
- 8) Does the device have an application part for protection against defibrillation discharge effects:
None;
- 9) Permanent installation equipment or non-permanent installation equipment: Non-permanent installation equipment;
- 10) Equipment type: Portable;

2.2 Performance

- Measuring range

- 1) Tonometer measuring range: 0.93kPa~8.0kPa.

- 2) Out of measuring range: prompt "OVER".

- Measuring accuracy

The measurement accuracy of the tonometer has a tolerance of $\pm 0.67\text{kPa}$.

- Measurement repeatability

The measurement repeatability of the tonometer should be less than 0.13kPa.

- Maximum jet pressure

The maximum jet pressure of the tonometer should not be greater than 11kPa (82.5 mmHg)

- Measuring range of corneal thickness (applicable to SK-5000B)

Corneal thickness measurement range: 0.4mm~0.8mm, the error is not more than $\pm 0.01\text{mm}$

- Appearance and structure requirements

The appearance of the tonometer should be tidy and free of burrs, the shell should be free from obvious damage or rust, and the text and logo on the panel should be clearly visible and firm.

The plastic parts of the tonometer should be free from blistering, cracking, deformation and overflow of the perfusion.

The operation and adjustment mechanism of the tonometer should be flexible and reliable, and the fasteners should not be loose.

- Structure and function

The function keys of the tonometer should be able to correctly perform the functions specified in

the instruction manual, and the input characters of the letter and number keys should be correct.

The tonometer has the functions of measuring intraocular pressure and corneal thickness (applicable to SK-5000B).

The tonometer has medical record management and graphic medical record report printing functions, which should meet the requirements of the instruction manual

Chin rest

1) The chin rest of the tonometer can be raised and lowered vertically, and the operation process should be smooth and without sudden jumps.

2) The lifting range of the chin rest is not less than 0mm~60mm.

Mobile platform

1) The mobile platform can move and stop arbitrarily, and the operation process should be smooth and without sudden jump.

2) The left and right adjustment range of the mobile platform is not less than 0mm~90mm, the front and back adjustment range is not less than 0mm~40mm, and the vertical lifting range is not less than 0mm~30mm.

● Software

Software function

1) The software should automatically judge the focus situation and control the air jet function;

2) The software should be able to collect data and calculate the intraocular pressure value;

3) The software should have a self-check program for the control equipment;

4) The software should have the function of clearing historical data and auto air jet demonstration;

5) The software should have the function of measuring corneal thickness (applicable to SK-5000B);

Cybersecurity requirements

Data interface

a) The software performs two-way data transmission through the network interface and the USB interface. The transmission protocols are TCP/IP and USB2.0 respectively.

b)The software uses U disk storage for electronic data exchange, and the storage format is .db.

Software manual

The release version of the software should be specified in the instruction manual, and all functions of the software should be reflected.

- Light radiation safety
 - 1) Infrared LED1 spectral range (Figure 1): wavelength 850nm;
 - 2) Infrared LED2 spectral range (Figure 2): wavelength 940nm;
 - 3) Blue LED spectral range (Figure 3): wavelength 460nm;



图 1 红外光 LED1 光谱图



图 2 红外光 LED2 光谱图

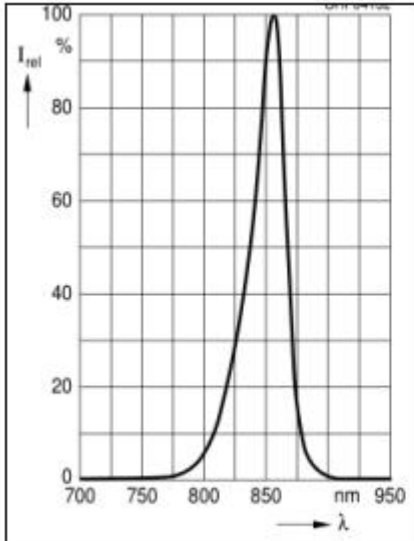

图 3 蓝光 LED 光谱图

4) The light source of the tonometer uses infrared LED and blue LED, which should meet the requirements of GB/T 20145-2006.

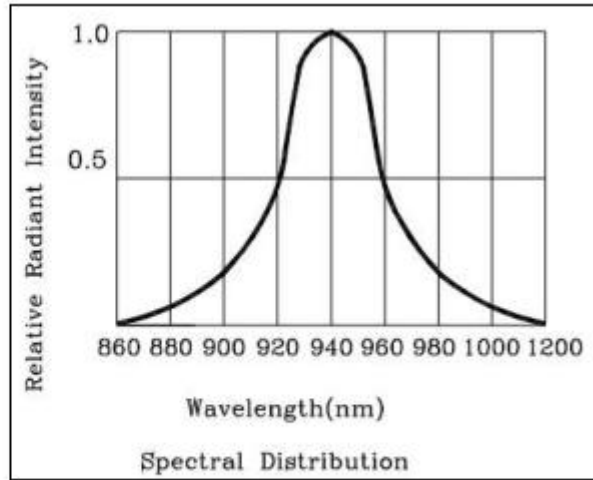
- Electrical safety requirements

The general safety requirements shall meet the requirements of the GB 9706.1-2007 standard.

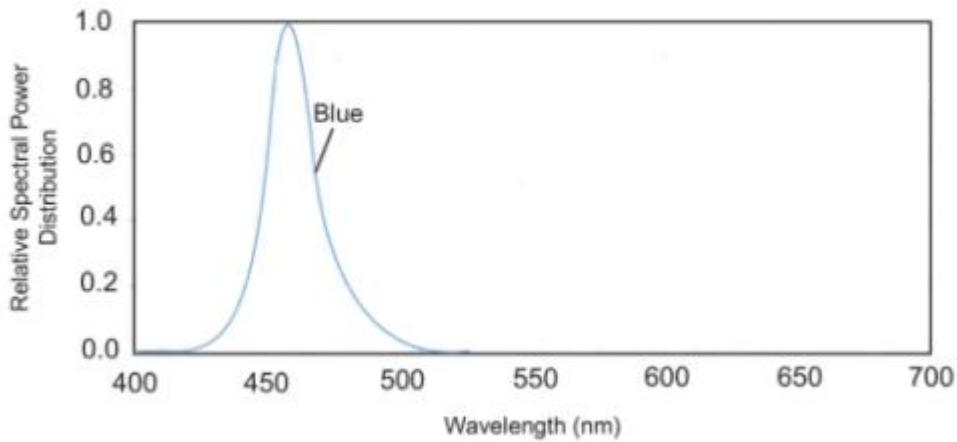
- Electromagnetic compatibility requirements

Electromagnetic compatibility should meet the requirements of YY 0505-2012 standard

- Environmental test requirements

The tonometer should meet the requirements of Climate Environment Group II and Mechanical Environment Group II in GB/T 14710-2009 and the requirements of figure2 in the technical requirements.

3.Equipment installation instructions

3.1 Product structure

1)Front view of host (Figure 4)

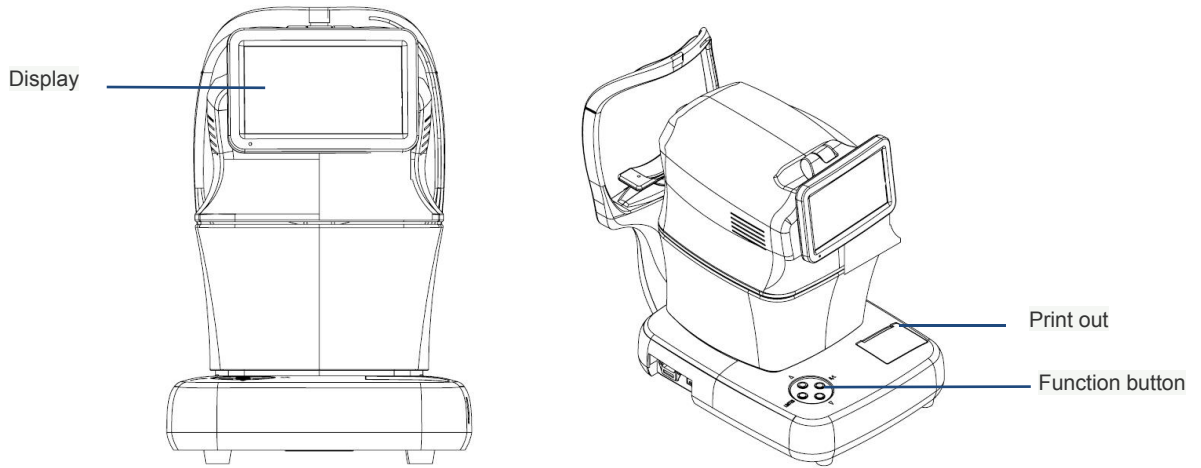

Figure 4 Front view of host

2) Side view of host (Figure 5,6)

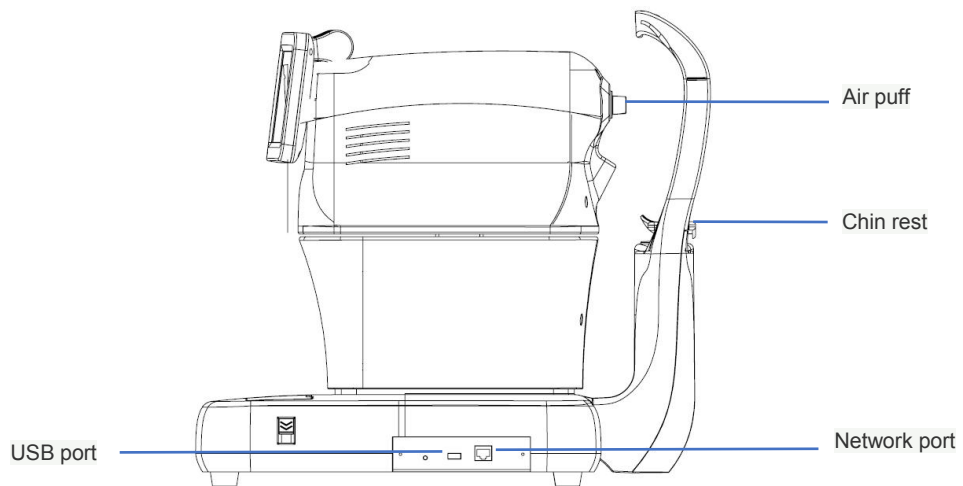

Figure 5 Side view of host

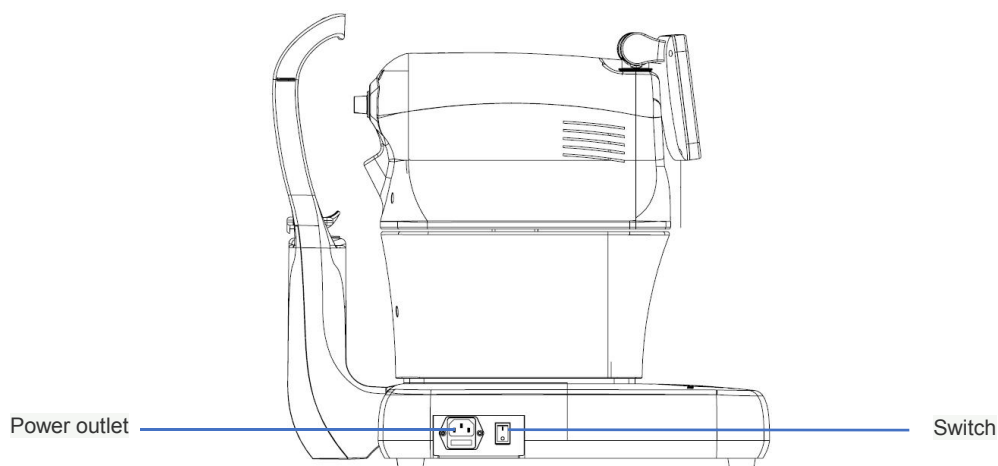

Figure 6 Right view of host

3.2 Equipment packaging and accessories description

3.2.1 Equipment packaging

This equipment is packaged in a special carton with special foam protection equipment for molding. As shown in Figure 7, when handling the equipment, be careful to handle it gently. The packaging box cannot be moved upside down. The equipment should be stored in a dry and clean environment.



Figure 7 Packaging diagram

3.2.1 Check accessories

Unpack the machine carefully, please check all accessories according to the following packing list before discarding the packing materials.

- (1) Non-contact tonometer host
- (2) Accessories: Power cord (Figure 8)



Figure 8 Power cord

- (3) Product qualification certificate, warranty card, receipt list, acceptance certificate.

3.3 Installation Environment

In order to ensure the safe and stable operation of the equipment, please ensure a good installation environment:

- (1) This equipment must be installed on a flat and non-inclined table.
- (2) This equipment must be installed in a clean, quiet and dry environment.
- (3) This equipment must be installed with a dedicated ground wire.
- (4) If the device encounters low temperature during transportation, do not open the package and do not turn on the power immediately.



Warning: If the device is in an ambient temperature close to 0°C, turning on the power directly will cause serious damage to the device.



Warning: When the first time unpacking, after unpacking, the device should be placed in a working environment for at least 8 hours to ensure that the components gradually heat up.

3.4 Installation

3.4.1 Placement of the main body of Non-contact tonometer

Take out the main body of the non-contact tonometer and place it on the table. Pay attention to it should be flat and not tilted, as shown in Figure 9.

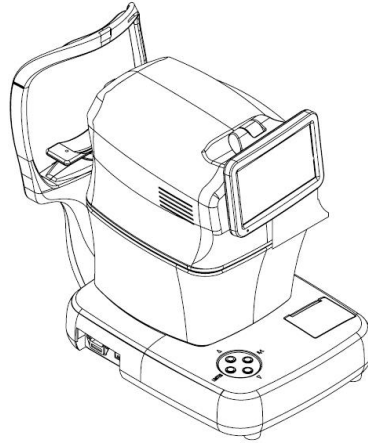

Figure 9 Host placement diagram

3.4.2 Connect the power cord

Power cord port

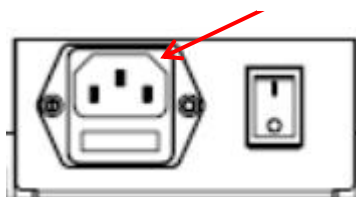

Figure 10 Power cord connection location

4.Introduction and settings of interface

4.1 Introduction of main interface

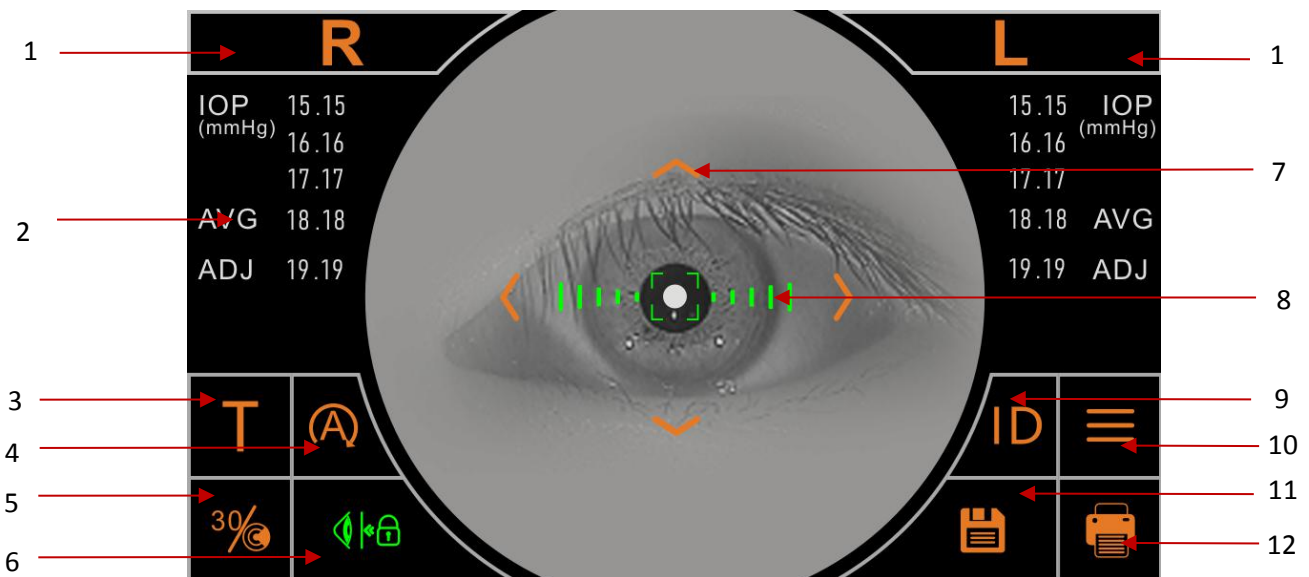

Figure 11 The main interface of the software

Note: Since the SK-5000B tonometer includes all the functions and structures of the SK-5000A tonometer, this manual mainly uses the SK-5000B tonometer as an example to explain, but the SK-5000A tonometer Customers can also refer to this manual.

Left and right eye selection.

1. Measurement data display.

IOP: measurement data of intraocular pressure;

AVG: the average value of all measured intraocular pressures;

ADJ: Correction value of intraocular pressure

P: The average value of corneal thickness measurement (only displayed in T/P mode).

2. Click the button to switch between T and T/P, T means only measuring intraocular pressure, the interface only displays intraocular pressure measurement data, T/P means measuring intraocular pressure and corneal thickness, and the interface displays the measurement of intraocular pressure and corneal thickness data.

3. Click the button to switch between manual, auto and fully auto.

A means that the measurement mode is automatic mode. In this mode, after the rough focus is completed, the machine will automatically focus accurately, and complete the test of one eye with air puff;



means that the measurement mode is fully automatic. In this mode, after the rough focus is completed, the machine will automatically focus accurately and complete the test of one eye with air puff, and then automatically complete the test of the other eye after completion;

M means that the measurement mode is manual mode. In this mode, the operator needs to manually complete focusing, air puff, measurement etc. When manual mode is selected, the measurement interface is shown in Figure 12.

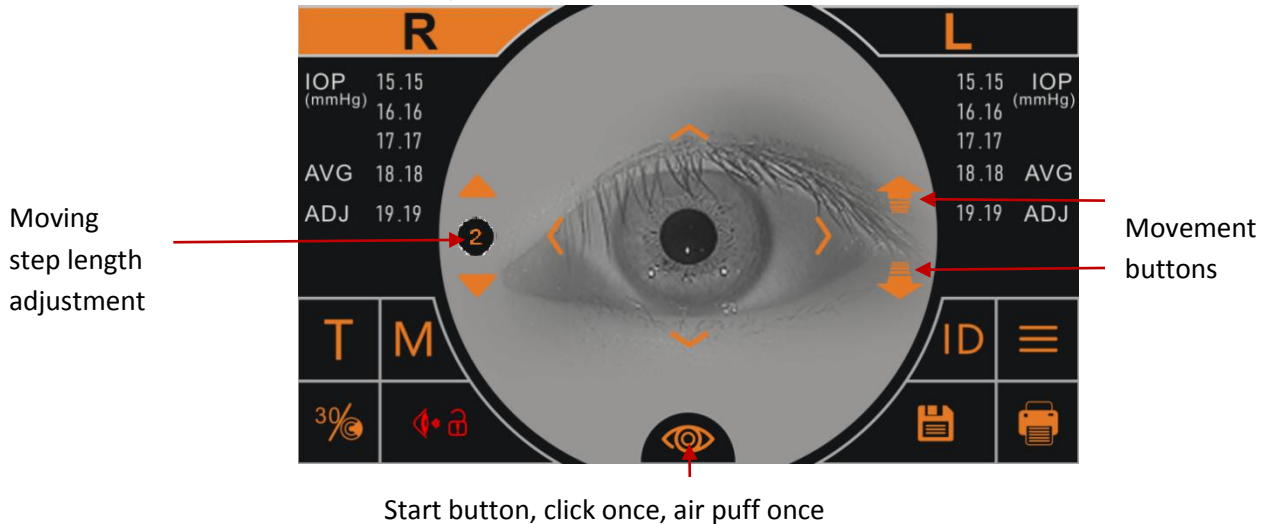

Start button, click once, air puff once

Figure 12 Manual mode measurement interface

4. Click the button to switch between 30 and 60. 30 means the measurement range is 0mmHg-30mmHg, and 60 means the measurement range is 0mmHg-60mmHg.

5. The safety distance setting button, the safety distance button turns green to indicate that the safety lock is open, the button color turns red, it means that the safety lock is closed. Click to enter the safety distance setting interface, as shown in Figure 13.

6. The control button can control the machine to move up, down, left, and right. When it moves to

the limit position in each direction, the arrow keys change to the forbidden movement style, and the click is invalid.

7. Alignment mark

There are three states of the alignment bar. When the alignment bar is green, it means that it has moved to the best position and you can start the air puff test. When the alignment bar is yellow, it means that the test head is too far away from the tested eye, and the software prompts the distance Too far, when the alignment bar is red, it means that the test head is too close to the tested eye, the software prompts that the distance is too close, and the buzzer sounds an alarm at the same time.

8. ID input button, click the button to enter the ID input interface.

9. Menu button, click it to pop up the menu interface.

10. Save button, click to save the current measurement data to the database.

11. Print button, click to print the measurement data.

4.2 Interface of safety distance setting

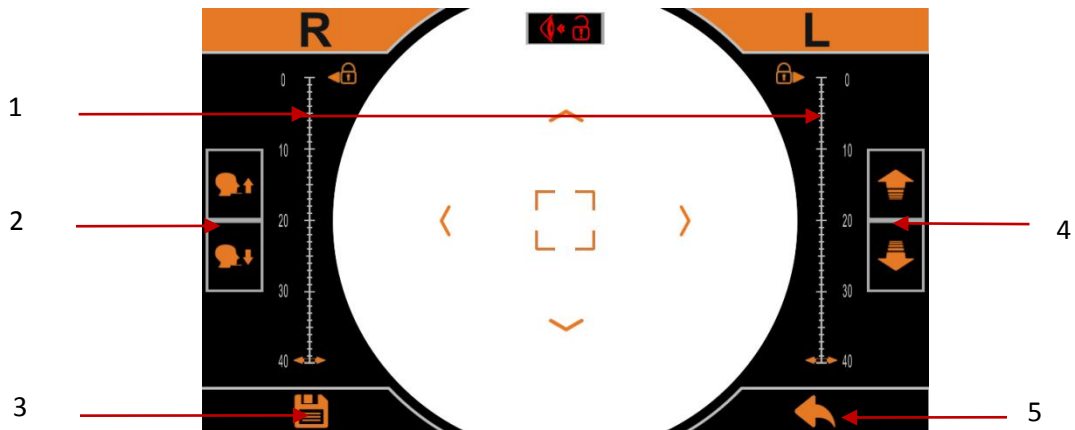

Figure 13 Interface of safety distance setting

1. Safety distance scale

2. Up and down adjustment buttons for the chin rest.

3. Save button, click to save the set safety distance.

4. Safety distance scale adjustment button.

5. Return button, click to return to the measurement interface

4.3 ID input interface



Figure 14 ID input interface

1. Input ID
2. Input Name
3. Input date of birth
4. Input corneal thickness
5. Return button, click to return to the test interface.
6. Clear button, click to clear all entered patient information.
7. Gender selection, click to switch gender.
8. After click the confirm button, the patient information enters the database and jumps to the test interface.
9. Worklist button, click to enter the worklist interface.

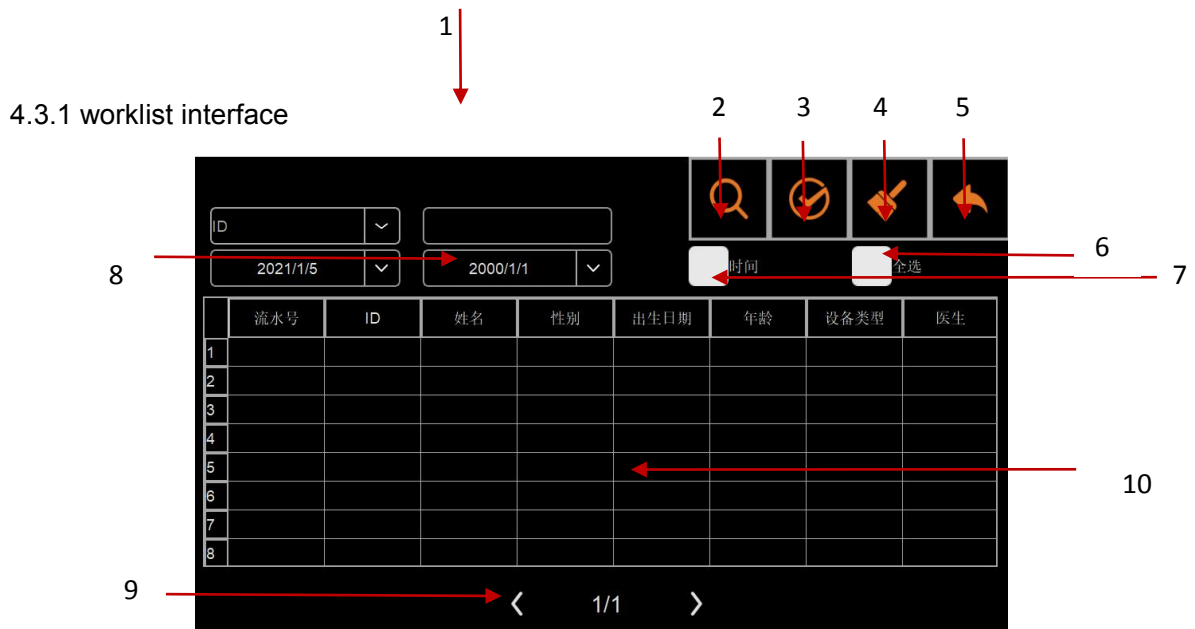

Figure 15 worklist interface

1. Selection and input of query conditions.
2. Search button, click to search according to input conditions.
3. Confirm button.

4. Clear button, click to delete the selected patient.
5. Return button, click to return to the ID interface.
6. Select all, select all patients in the patient list.
7. Time period selection, select the start time and end time.
8. Choose start and end time.
9. Page turn button, click it to page up and page down.
10. Information of patient list.

4.4 Menu interface

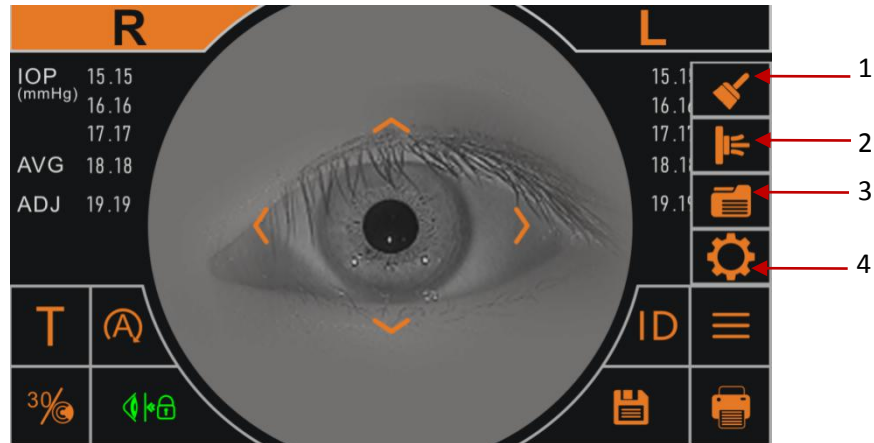

Figure 16 Menu interface

1. Clear button, click to clear measurement data.
2. Air detection button. Before starting the test, click the button, and air will automatically be jet from the air puff
3. Click to enter the database interface.
4. Click to enter the setting interface.

4.4.1 Database interface



Figure 17 Database interface

1. To select and input query conditions, click the down arrow on the right side to call up the search item selection drop-down menu. There are three search item selection items "ID", "Name", and

"Date of Birth" in the drop-down menu.

2. Database list.
3. Page turn button, click it to page up and page down.
4. Return button, click to return to the test interface.
5. Details button, click to enter the details interface.
6. Recheck button, after selecting a certain group of data, click the button to enter the test interface.
7. Delete button, click to delete the selected patient data.
8. Export button, click to export the data to U disk, you can export one piece of data or multiple pieces of data.
9. Import button can import external data into the database.

4.4.1.1 Details interface

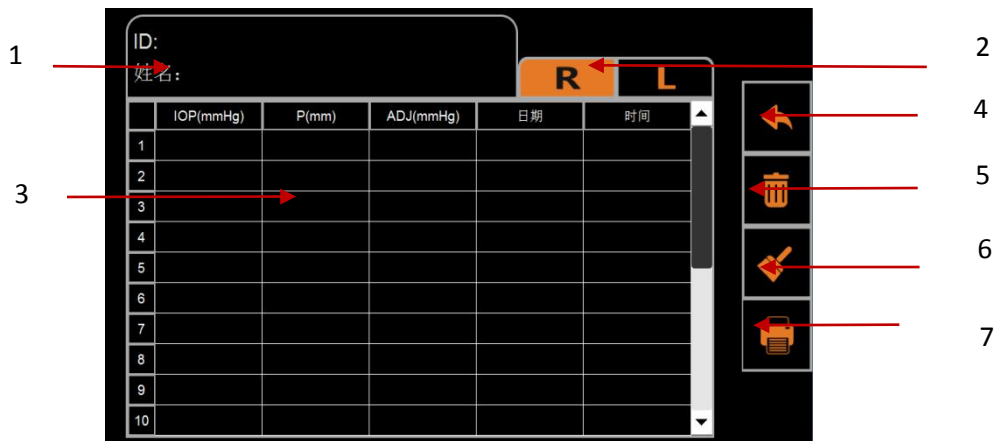

Figure 18 Details interface

1. Information of patient
2. Switch between left and right eyes.
3. Display of detailed measurement data of a certain patient. When the right eye is selected, all the measurement data of the right eye are displayed; when the left eye is selected, all the measurement data of the left eye are displayed (IOP data shows the average value).
4. Return button, click to return to the previous interface.
5. Delete button, click to delete the selected data.
6. Clear button, click to clear all data.
7. Print button, click to print out the selected data.

4.4.2 settings interface.



11

Figure 19 Settings interface

1. General settings.
2. Check the settings.
3. IP settings.
4. Print settings.
5. Display settings.
6. Reset button, click to restore all setting items to factory settings.
7. About button, click to enter the about interface.
8. Reset Button,click this button,the machine will return to original factory setting position.
9. Save button, click to save the settings
- 10.Return button, click to return to the test interface.
- 11.Enter the keyboard.
- 12.Page turn button, click it to page up and page down.
- 13.The detailed setting items are as follows.

Form 4 General settings

Item	Settable value	Description
Date format	Y-M-D	Set the time format as year, month, day
	M-D-Y	Set the time format as month, day, year
	D-M-Y	Set the time format as day, month, year
Date	/	Enter according to the date format
Time	/	Enter hours (24 hours), minutes, and seconds
Language	Chinese	Software display language is Chinese
	Russian	Software display language is Russian
	English	Software display language is English
	French	Software display language is French
	Spanish	Software display language is Spanish
Buzzer prompt	Turn on	Buzzer prompts to turn on
	Turn off	Buzzer prompts to turn off
Screen brightness	Low	Low brightness
	Medium	Medium brightness
	High	High brightness
	Highest	Maximum brightness
Sleep time	Turn off	Do not use sleep
	5min	The machine enters sleep mode after 5 minutes of inactivity
	10min	The machine enters sleep mode after 10 minutes of inactivity
	20min	The machine enters sleep mode after 20 minutes of inactivity
	30min	The machine enters sleep mode after

		30 minutes of inactivity
	60min	The machine enters sleep mode after 60 minutes of inactivity
Screen brightness	Low	Low brightness
	Medium	Medium brightness
	High	High brightness
	Highest	Maximum brightness
Buzzer volume	Turn off	Turn off the buzzer
	Low	Low volume
	Medium	Medium volume
	High	High volume

Form 5 Check the settings

Item	Settable value	Description
Interpupillary distance	User input	The value entered by the user is in mm
Moving distance	User input	moving step length of motor
Corneal basal value (μm)	User input	/
Adjusted coefficient	User input	/
Measurement mode	Automatic	Set the measurement mode to automatic mode
	Manual	Set the measurement mode to manual mode
	Fully automatic	Set the measurement mode to fully automatic mode
Waiting position after measurement	Right	Waiting at the initial position of the right eye
	Left	Waiting at the initial position of the left eye
	Last measurement position	Waiting at the position of the tested eye
Number of IOP measurements	1	1 time IOP measurement
	2	2 times IOP measurement
	3	3 times IOP measurement
Measurement type	T	Only measure intraocular pressure
	T/P	Measure intraocular pressure and corneal thickness
IOP measurement range	0-30	The measuring range is 0mmHg-30mmHg
	0-60	The measuring range is

		0mmHg-60mmHg
--	--	--------------

Form 6 IP settings

Item	Settable value	Description
IP	Input settings	/
Mask	Input settings	/
Gate	Input settings	/
DNS	Input settings	/
Dicom	Input settings	/

Form 7 Print settings

Item	Settable value	Description
Automatic printing	Open	Automatically print the result after the measurement.
	Close	The results will not be printed automatically after the measurement.
Print ID	Open	Print patient ID
	Close	Do not print patient ID
Print correction value of IOP	Open	Print correction value of intraocular pressure
	Close	Do not print correction value of intraocular pressure

Form 8 Display settings

Item	Settable value	Description
Show the picture of corneal	Open	Display corneal picture
	Close	Do not display corneal pictures
Display error message	Open	Display error message
	Close	Do not display error messages
Display low reliability value	Open	Display low reliability value
	Close	Do not display low reliability values
IOP display unit	mmHg	Display unit is mmHg
	kPa	Display unit is kPa
Corneal display unit	mm	Display unit is mm
	μm	Display unit is μm
Display the correction value of IOP	Open	Display the correction value of IOP
	Close	Do not display the correction value of IOP

5. Instructions for operating

5.1 Software description

5.1.1 Software name: Sunkingdom non-contact tonometer system software

Software model: SK-5000

5.1.2 Software release version number: V1.0

5.1.3 Software provider

Name of software provider: CHONGQING SUNKINGDOM MEDICAL INSTRUMENT CO.,

Software provider address::

35-2, YINGTIANGUANGDIANGONGGU, CAIJIAGANG INDUSTRY, B
EIBEI DISTRICT, CHONGQING, China

5.1.4 Software Support

CHONGQING SUNKINGDOM MEDICAL INSTRUMENT CO., provides technical support,
provides software operation training for software users, and
continues to upgrade and optimize the operation software.

5.2 IOP/Corneal measurement

1) Confirm that the power cord is connected.

2) Turn on the power of the main body to enter the main page.

**3) Click the "ID" button to enter patient information, or
directly perform measurement without entering ID.**

4) Set the measurement mode and the number of air puff as needed.

5) Click the air check button to check whether there is any foreign matter at the air puff

6) Confirm that the eye height mark is at the center.

7) The patient sits in front of the device. Adjust the height of the adjustable equipment table or chair so that the patient can comfortably place the jaw on the chin rest.

- 8) Adjust the height of the chin rest until the patient's eye height is consistent with the eye height mark on the chin rest. At this time, confirm that the patient's sight height is consistent with the height mark of the measurement window.
- 9) Click the safety braking button to set the safe braking distance of the test eye.
- 10) Start testing.
- 11) Print the result after the test is completed.

6. Maintenance of Equipment

6.1 Daily maintenance



Warning: Before wiping the equipment, disconnect the AC power supply.



Warning: Every time the device is shut down, the AC power supply should be disconnected.



Warning: The touch screen is easily damaged. You can only wipe it with a damp cloth, not solvents or alcohol.

In order to ensure automatic calibration and obtain accurate measurement values, the measurement window glass should be cleaned after work every day.

6.2 Maintenance during equipment operation

When the equipment is running, it is best not to have strong sound, light, electricity, magnetism and other interference around.

6.3 Maintenance of long-term parking equipment

When keeping it idle, the equipment should be wiped, and then covered with a clean cloth or polyethylene film, wrapped, or pack it in the box.

In order to protect the shell, do not use abrasive clean tools. If possible, remove stains before the case dries.

6.4 Parts replacement

The hospital can repair or replace the parts by itself (must use the parts designated by our company).

6.4.1 Fuse type and rating: T2AL250V (the fuse must meet the requirements of the national standard GB 9364).

Note: When replacing the fuse, you need to disconnect the power first and open the fuse box to replace it.

6.4.2 Thermal paper: thermal paper with a width of 110mm.

6.4.3 If the user needs, we can provide related technical drawings and circuit diagrams for maintenance.

6.5 Waste disposal

During the normal use and maintenance of this equipment, the replaced parts or other waste should be properly disposed of in accordance with the requirements of local laws and regulations, and should not be discarded at will. At the end of its life, the equipment should be recycled in accordance with local laws and regulations to avoid environmental pollution.

6.6 Manufacturer's responsibility

The manufacturer is only responsible for the safety and reliability of this equipment under the following conditions:

- Assembly, addition, debugging, modification or maintenance are all carried out by personnel approved by the company;
- The electrical facilities in the room meet the relevant requirements;
- The equipment is used in accordance with the requirements of the instruction manual.

6.7 Common troubleshooting

Form 9 Common troubleshooting

Malfunction	Situation	Check
No display on the control panel	_____	Confirm whether the power plug is properly inserted.
	_____	Confirm if the device is connected to power.
	The fuse is broken after power on	Contact with our company's after-sales service personnel.
Can't see clear the control panel	The image is dark	Adjust brightness.
The moving part is faulty	_____	Please do not move forcefully, contact with our after-sales service personnel.
Can't print	The output paper has no content	Confirm that the paper roll is correct.
	No paper output	Confirm whether the printer is out of paper, if it is out of paper, replace with new paper.

7. Information requirements of Electromagnetic compatibility

7.1 Equipment classification

Non-contact tonometers are classified according to the national standard GB 4824 and belong to Group 1 Class A equipment.

7.2 Basic performance

The non-contact tonometer shall meet the following requirements under the test conditions specified in 36.202 of YY 0505:

- 1) The system can maintain its set working status without crashes, working mode changes or other malfunctions. The measurement function should be able to be used normally and the noise, artifact or distortion of the waveform in the image cannot be attributed to physiological effects and cannot change the diagnosis conclusion.

7.3 Electromagnetic emission

Guide and manufacturer's declaration——Electromagnetic emission		
The non-contact tonometer is expected to be used in the following electromagnetic environment, and the purchaser or user should ensure that it is used in this electromagnetic environment:		
Emission test	Applicable	Electromagnetic environment——guide
Radio frequency emission GB 4824 (CISPR 11)	Team 1	<p>The non-contact tonometer uses radio frequency energy only for its internal function. Therefore, its radio frequency emission is very low, and the possibility of causing interference to nearby electronic equipment is very small.</p> <p>The non-contact tonometer is suitable for use in non-domestic and all facilities that are not directly connected to the public low-voltage power supply network of domestic residences.</p>
Radio frequency emission GB 4824 (CISPR 11)	Class A	
Harmonic radiation GB 17625.1	Not applicable	
Voltage fluctuation/flicker emission GB 17625.2 (IEC	Not applicable	

61000-3-3)

7.4 Electro Magnetic Immunity

Guide and manufacturer's declaration—— Electro magnetic immunity			
<p>The non-contact tonometer is expected to be used in the following electromagnetic environment, and the purchaser or user should ensure that it is used in this electromagnetic environment:</p>			
Immunity test	IEC60601 Test level	Coincidence level	Electromagnetic environment-guide
Electrostatics Discharge (ESD) GB/T 17626.2 (IEC61000-4-2)	±6kV contact discharge ±8kV air discharge	±6kV contact ±8kV air	The floor should be wood, concrete or ceramic tiles. If the floor is covered with synthetic material, the relative humidity should be at least 30%.
Electrical Fast Transient GB/T 17626.4 (IEC61000-4-4)	±2kV to power cord ±1kV to input/output line	±2kV to power cord ±1kV to input/output line	The network power supply should have the quality used in a typical commercial or hospital environment.
Electrical surge GB/T 17626.5 (IEC61000-4-5)	±1kV line to line ±2kV line to ground	±1kV line to line ±2kV line to ground	The network power supply should have the quality used in a typical commercial or hospital environment.
Voltage dips, short-term interruptions and voltage changes on the power input line GB/T 17626.11 (IEC61000-4-11)	<5% UT for 0.5 cycle (on UT, > 95% dip) 40% UT for 5 cycles (at UT, 60% dip) 70% UT, for 25 cycles (at UT, 30% dip) <5% UT for 5s (On UT, > 95% dip)	<5% UT for 0.5 cycle (at UT, > 95% dip) 40% UT for 5 cycles (at UT, 60% dip) 70% UT, for 25 cycles (at UT, 30% dip) <5% UT for 5s (On UT, > 95% dip)	The network power supply should have the quality used in a typical commercial or hospital environment. If the user of the non-contact tonometer needs continuous operation during the power interruption, it is recommended that use uninterrupted power supply or battery power supply.
Power frequency magnetic field	3 A/m	3 A/m	The power frequency magnetic field should have

(50/60Hz) GB/T 17262.8 (IEC 61000-4-8)			the level of the power frequency magnetic field in a typical commercial or hospital environment.
Note: UT refers to the AC network voltage before the test voltage is applied.			

7.5 EMI----For non-life support equipment and systems

Guide and manufacturer's declaration—— Electro magnetic immunity The non-contact tonometer is expected to be used in the following electromagnetic environment, and the purchaser or user should ensure that it is used in this electromagnetic environment:			
Immunity test	IEC60601 Test level	Coincidence level	Electromagnetic environment-guide
Radio frequency conduction GB/T 17262.6 (IEC61000-4-6) Radio frequency radiation GB/T 17262.3 (IEC61000-4-3)	3 V (Effective value) 150kHz - 80MHz 3 V/m 80MHz - 2.5GHz	3 V (Effective value) 3 V/m	Portable and mobile radio frequency communication equipment should not be used closer to any part of the non-contact tonometer, including cables, than the recommended isolation distance. The distance is calculated by the formula corresponding to the frequency of the transmitter Recommended isolation distance: d =1.2 150kHz-80MHz d =1.2 80MHz-800MHz d =2.3 800MHz-2.5GHz formula: P——According to the maximum rated output power of the transmitter provided by the transmitter manufacturer, in watts (W); d—— is the recommended isolation distance, in meters (m). The field intensity of the fixed radio frequency transmitter is determined by surveying the electromagnetic field a, and should be lower than the compliance level b in each frequency range. Interference may occur in the vicinity of equipment marked with the following symbols.



Note 1: At 80MHz and 800MHz, use the higher frequency band formula.

Note 2: These guides may not be suitable for all situations. Electromagnetic propagation is affected by absorption and reflection from buildings, objects, and humans.

^aFixed transmitters, such as: base stations for wireless (cellular/cordless) phones and terrestrial mobile radios, amateur radio, AM and FM radio broadcasts, and TV broadcasts, whose field intensity cannot be accurately predicted in theory. In order to assess the electromagnetic environment of fixed radio frequency transmitters, electromagnetic field surveys should be considered. If the measured field intensity of **the non-contact tonometer** is higher than the above applicable RF compliance level, **the non-contact tonometer** should be observed to verify its normal operation. If abnormal performance is observed, supplementary measures may be necessary, such as readjusting the direction or position of **the non-contact tonometer**.

^b At frequency range of 150kHz-80MHz, the field intensity should be less than 3V/m.

7.6 Recommended isolation distance between portable and mobile RF communication equipment and non-contact tonometer

Recommended isolation distance between portable and mobile radio frequency communication equipment and non-contact tonometer

The non-contact tonometer is expected to be used in an electromagnetic environment where radio frequency radiation disturbance is controlled. According to the maximum rated output power of the communication equipment, the purchaser or user can prevent electromagnetic interference by maintaining the minimum distance between the portable and mobile radio frequency communication equipment (transmitter) and the non-contact tonometer as recommended below

Max rated output power of transmitter W	Corresponding to the isolation distance of different frequencies/m		
	150kHz - 80MHz d = 1.2	80MHz - 800MHz d = 1.2	800MHz - 2.5GHz d = 2.3
0.01	0.12	0.12	0.23
0.1	0.38	0.38	0.73
1	1.2	1.2	2.3
10	3.8	3.8	7.3
100	12	12	23

For the Max rated output power of the transmitter not listed in the form, the recommended isolation distance d, in meters (m), can be determined by the formula in the corresponding transmitter frequency column, P is the emission provided by the transmitter manufacturer the Max rated output power of the machine. The unit is in watts (W)..

Note 1: At 80MHz and 800MHz, use the higher frequency band formula

Note 2: These guides may not be suitable for all situations. Electromagnetic propagation is affected by absorption and reflection from buildings, objects, and humans. .

7.7 Installation Environment

The non-contact tonometers are used in non-domestic and hospital-specific low-voltage power supply grids that are not directly connected to the public low-voltage power supply network of domestic. The socket should have reliable protective grounding measures, and use the supplied power cord, parts and accessories. The floor should be wood, concrete or ceramic tiles. If the floor is covered with synthetic material, the relative humidity should be at least 30%. Other equipment used at the same time near this equipment should meet the requirements of electromagnetic compatibility.

For the possible impact of portable and mobile radio frequency communication equipment on non-contact tonometers, for details, please read "7.6 Recommended isolation distance between portable and mobile RF communication equipment and non-contact tonometer".

The non-contact tonometer is limited to the power cord, parts and accessories provided by the manufacturer (see the list of accessories in form10 for details). When using these power cords, parts and accessories, it meets the requirements of 36.201 and 36.202 in YY 0505.

Warning: Except for the accessories and cables sold by the system manufacturer as internal components, use accessories and cables outside the regulations may result in an increase in system emission or a decrease in immunity.

Warning: The use of accessories or cables outside the regulations with the system may result in an increase in system emission or a decrease in immunity.

Warning: The system should not be used close to or stacked with other equipment. If it must be used close or stacked, it should be observed to verify that it can operate normally under the configuration used.

Warning: When the system is used near the equipment marked with , it may be interfered by it and the basic performance and safety may be reduced.

7.8 Appurtenance list

Form 10 Appurtenance list

NO.	Accessories	Model	Parameter
1	Power cable	3×0.75 mm ²	Length:1.8 m

CHONGQING SUNKINGDOM MEDICAL INSTRUMENT CO.LTD.

			Unshielded twisted pair
2	Switch	RPS-200-24-C	INPUT:80-264VAC OUTPUT:+24VDC
3	Magnetic ring	ZCAT3035-1330	Φ13
4	Magnetic ring	ZCAT2035-0930A	Φ9
5	Magnetic ring	ZCAT2132-1130	Φ11
6	Magnetic ring	ZCAT1518-0730	Φ7

8.Warranty statement

Commitment: The manufacturer can provide the necessary data for the repairable equipment parts designated by the manufacturer.

1. Our company will provide equipment maintenance and free consultation for life.

Before contact our company by telephone, we suggest that you clarify the following information:

- The name and model of the device you are using.
- The number of the device you are using.
- An accurate description of the information displayed on the screen.
- What happened and what were you doing when it happened.
- What measures have you taken to solve this problem.

2.Under the premise of operating in accordance with this instruction manual, this product has a free warranty for one year from the date of purchase.

3.Under normal use in accordance with the instructions for use and the precautions for operation inside the machine.Once the machine fails, please contact our company immediately.

4.The following content is not covered by the warranty:

- ∞ Use, maintenance, and storage without following instruction, and causes damage.
- ∞ Without authorized by Chongqing Sunkingdom Medical Instrument Co., Ltd. privately dismantle/modify and cause damage to the equipment.
- ∞ The equipment is damaged due to accidents, operate miss, or irresistible natural factors.

Note: 1.Failure to follow the operation steps or irregular operation causes a medical accident,the company does not assume medical responsibility.

2.The final interpretation of this instruction manual belongs to Chongqing Sunkingdom Medical Instrument Co., Ltd. , and it is subject to modification without notice.

Manufacturing company name: CHONGQING SUNKINGDOM MEDICAL INSTRUMENT CO.LTD.

Registered address of the company: No. 1 Xinmao Road, Beibei District, Chongqing (FTA)

Manufacture address:

35-2,YINGTIANGUANGDIANGONGGU,CAIJIAGANG INDUSTRY,BEIBEI DISTRICT, CHONGQING

Tel: 023-68102805

Supervise Tel: 023-68102791

Fax: 023-86034333

Postcode: 400700

Website: www.cqsunkingdom.com